

---

**-AXITEC®**

# Installation and Operating Guide

## Solar Modules

### Production Series AC

ENERGY FOR A BETTER WORLD



# INDEX

<b>1. INTRODUCTION</b> .....	<b>3</b>
<b>2. CODES AND REGULATIONS</b> .....	<b>3</b>
<b>3. GENERAL INFORMATION</b> .....	<b>4</b>
3.1 Product Identification.....	4
3.2 General regulations and safety rules .....	5
3.3 Fire Protection .....	6
<b>4. INSTALLATION AND ASSEMBLY RULES</b> .....	<b>7</b>
4.1 Assembly Notes.....	7
4.2 Location selection .....	8
4.3 Alignment .....	8
<b>5. MECHANICAL INSTALLATION</b> .....	<b>9</b>
5.1 Installation with clamps .....	9
5.2 Installation using mounting holes .....	12
5.3 Installation with insertion systems.....	12
<b>6. ELECTRICAL INSTALLATION</b> .....	<b>13</b>
6.1 Electrical property .....	13
6.2 Bypass diode .....	15
6.3 Grounding.....	15
<b>7. MAINTENANCE AND CLEANING</b> .....	<b>16</b>
7.1 Maintenance .....	16
7.2 Cleaning.....	16
<b>8. DISCLAIMER OF LIABILITY</b> .....	<b>17</b>



**Please read the installation manual before using or installing Axitec LLC modules. Solar modules produce electricity when exposed to sunlight. Follow all applicable electrical safety precautions. Only qualified personnel should install or perform maintenance work on modules. Do not damage or scratch the rear surface of the module. Do not handle modules when they are wet, may increase the risk of electrical shock.**

## **1. INTRODUCTION**

Thank you for choosing AXITEC LLC solar modules. With proper operation and maintenance, AXITEC LLC modules will provide you with clean and renewable solar electricity for years to come. This manual contains necessary installation, maintenance, and safety information. Keep this guide in a safe place for future reference.

Non-compliance with this installation instruction may result in property damage and/or physical injury. AXITEC LLC will not be liable for compensation of any loss or injury caused by this type of non-compliance.

AXITEC LLC reserves the right to make unannounced alterations to the design and/or technical specifications of its solar modules at any time. Therefore, only the datasheet current at the time of manufacture is definitive. It is therefore expressly recommended to ensure that the datasheets on hand represent the current status before placing an order. When performing assembly or other work on the solar modules, the datasheets and user information current at the time of manufacture of the relevant module are to be used for reference. The contents of older or newer documents may be incorrect due to interim product changes.

**This version of “Installation & Operating Instructions” replaced all other before.**

## **2. CODES AND REGULATIONS**

The mechanical and electrical installation of PV systems should be performed in accordance with all applicable codes, including electrical codes, building codes and electric utility interconnection requirements. Such requirement may vary for mounting location. Requirements may also vary with system voltage, and for DC or AC application. Contact local authorities for governing regulations. If not otherwise specified, it is recommended that the requirements of the U.S. National Electrical Code (NEC) or respective European Code and other countries Code be followed.

### 3. GENERAL INFORMATION

#### 3.1 PRODUCT IDENTIFICATION

Each module has four labels

**1x name plate:**

Describes product type, nominal power, nominal current, nominal voltage, no-load voltage, short-circuit current (measured under standard test conditions (STC), the measurement tolerance is +/- 3%), weight, dimensions, etc. The maximum system voltage is 1000 or 1500 V DC, depending on the Modul type.

**3x serial number/barcode:**

Each module has a unique serial number encoding, among other details, the year and month of manufacture. One serial number label is permanently fitted on the front below the glass, one Label with serial number and barcode is on the rear below / next to the type label and one with serial number and barcode is on the frame.



Monofacial Glass-Foil

bifacial

Monofacial double glass

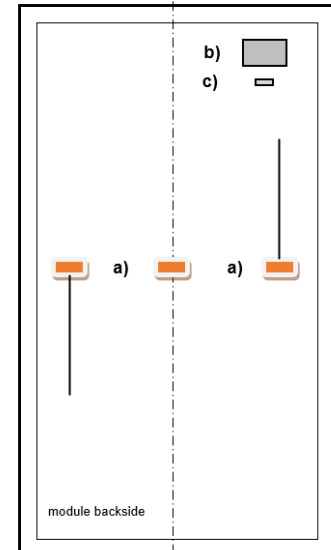
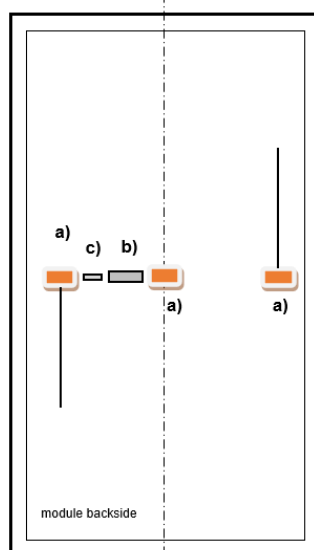
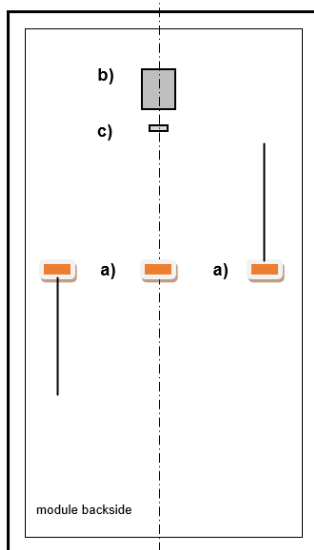

a) Junction Box

b) Name Plate

c) Serial Number

### **3.2 GENERAL REGULATIONS AND SAFETY RULES**

Before the start of the installation of the PV system, the advice of the relevant authorities as well as the energy provider regarding regulations, guidelines and approval requirements must be obtained. These are to be followed during installation. All applicable local, regional, and national statutory orders and regulations are to be observed.

An improper execution during installation or commissioning can result in personal injuries or damage to the modules.

It is advisable to provide for service access during project planning.

Protective goggles and safety shoes are to be worn at all times when performing the work. If applicable, observe the regulations and recommendations of the relevant trade associations or corresponding bodies. Work on the photovoltaic system must not be performed in rain, snow, or wind. The glass surface and module frame can become hot when exposed to sunlight and there is a risk of burns. Use gloves, if applicable.

For safety reasons, defective modules must be replaced immediately.

The photovoltaic modules from AXITEC LLC described herein meet the requirements of application class A, that is, dangerous voltage (IEC 61730: greater than 50 V DC or greater than 240 W; EN 61730: greater than 120 V DC) and systems with dangerous power output, where unrestricted accessibility is to be expected.

Solar modules produce electrical energy when exposed to sunlight. DC voltages may exceed 30V on a single exposed Solar module.

Only connect Solar modules with the same rated output current in series. If Solar modules are connected in series, the total voltage is equal to the sum of the individual Solar module voltages. You can find the maximum system voltage for Solar module type on the datasheet. For roof use, the maximum system voltage must not exceed 1000V according to National Electrical Code.

The modules must not be immersed in water.

Do not artificially bundle sunlight by means of mirrors, lenses, or other devices onto the module.

If the modules are installed according to the instructions above, the system components must result in a proper operation of the modules. If the modules are not operated properly, the warranty can become void or at least significantly limited.

Further information about modules from AXITEC LLC can be found in the datasheets for the solar modules. The datasheets are available via the Internet at [www.axitecsolar.com/us](http://www.axitecsolar.com/us)

### **3.3 FIRE PROTECTION**

For questions regarding building safety and prevention of fires on buildings please contact the relevant local authority.

If applicable, use earth fault switches or fuses in accordance with the specifications of the local authorities.

Do not use solar modules near devices or places where flammable gases may be formed.

In a roof installation, the solar module must only be mounted above a fireproof roof cover approved for this application.

Our modules comply with fire protection class C according to IEC 61730-2. As a rule, it can be assumed that a fire risk can be assessed as low in any case on roofs made of building materials of class A, i.e. non-combustible, according to DIN EN 13501, if our modules are installed properly. When installed on a roof, the module may only be mounted over a fireproof roof covering approved for this application. It must also be ensured that the rear panel and the mounting surface are fully ventilated. Improper installation can lead to a fire hazard. To ensure the fire resistance of the roof, a distance of  $\geq 10$  cm between the module frame and the roof surface is recommended. However, it must be checked separately on site in each individual case to what extent installation of the modules is possible in accordance with the respective fire protection regulations and whether additional measures must be taken if necessary. The responsibility for professional installation in compliance with the regulations always lies with the installing company.

## **4. INSTALLATION AND ASSEMBLY RULES**

### **4.1 ASSEMBLY NOTES**

Do not open AXITEC LLC Package while in transportation or in and storage process unless the solar modules have arrived at the installation site.

Do not damage the package and do not drop packaged solar modules.

Do not exceed the highest layer limit indicated on the packaging carton when stacking solar modules up.

Store packaging carton in ventilated, rain-proof and dry places before unpacking of solar modules.

The glass surfaces must not be damaged or scratched. In particular, the rear of the solar module must not be exposed to mechanical impacts (e.g. by sharp, hard objects).

Do not stand on the solar modules or solar module frames.

The solar modules must not be installed under bending tension and the frame parts must not be twisted in themselves during assembly.

The solar module must not be compressed along its sides.

Solar modules must be handled with care during installation. Impacts to the front and rear or the edges can damage the solar modules.

For a roof assembly, ensure that the structural dimensions (consult a structural engineer, if applicable) of the roof are adequate for bearing the loads imposed by the photovoltaic system.

Do not drill any holes into the solar module and solar module frame.

Do not repair glass or solar modules, which backsheets are damaged, on your own.

Do not try to disassemble the solar modules or remove nameplate or parts of solar modules. Doing so will void the warranty.

To ensure sufficient rear ventilation, a gap of at least 10 cm between the underside of the frame and the roof cladding is recommended. Solar modules become warm and require an adequate air flow for cooling. When installing a solar module on a roof or building, ensure that it is securely fastened and cannot fall as a result of wind or snow loads. Provide adequate ventilation under a solar module for cooling (10cm minimum air space between solar module and mounting surface recommended). Slope should be less than 5 in/ft (127 mm/305 mm) required to maintain a fire Class rating.

Water drainage openings in the solar module frame must not be closed in any way. The mounting frame, too, must not obstruct them. The earthing holes provided only serve for the purpose of earthing the frame.

## **4.2 LOCATION SELECTION**

Marine and mobile applications are generally excluded. Floating installations only after consultation with AXITEC.

If the solar modules are assembled near the sea, a minimum distance of 500 m / 1640 ft to the coastline must be ensured.

Solar modules may not be installed above 2,000 m / 6562 ft above sea level.

Select a suitable location for installation of the solar module. The solar module should be facing true south in northern latitudes and true north in southern latitudes for best power production.

Glare caused by solar modules cannot be ruled out. Solar modules must therefore not be installed in locations where glare could pose a potential risk.

Operation of the solar modules in regions with snow loads of up to 3600 Pa is dependent on the assembly and solar module type (see 5. Mechanical Installation).

Ensure that no flammable gases can occur near the installation site.

The solar modules must be installed in an environment in which it is ensured that the operating temperature range will not exceed or fall below -40°C to +85°C. Sufficient air circulation behind the solar modules should particularly be ensured in hot environments.

All shading of the module array is to be avoided. The modules must not be permanently shaded (including partial shading, spot shading, uniform shading or uneven shading). Permanent shading means that the cells are continuously shaded over a longer period of time, e.g. when modules are installed behind a pipe, a chimney, a tree, etc. If a defect (e.g. a hot spot) is caused by improper installation of a module in the shade or by poor maintenance, the warranty is void. The power loss in fully or partially shaded cells leads to power loss, reduced yield and can lead to localized overheating, which in turn can have a negative effect on the service life of the modules. Permanent shading can lead to accelerated ageing of the encapsulation material and cause thermal stress on the bypass diodes. If modules are nevertheless installed in such shaded areas, optimizers are required at module level (MLPE).

## **4.3 ALIGNMENT**

If possible, all solar modules should be aligned in the same way.

The solar modules are suitable for installation both with their long side up and their short side up. (see 5. Mechanical Installation)

The solar modules are to be mounted in such a way that melt- and rainwater can run off freely and that the solar module will not be constantly wet.

To increase the yield of the rear side of bifacial solar modules, shading by the substructure should be avoided as far as possible. A substrate with a high albedo and an increased distance between the solar module and the substrate also have a positive effect on the energy yield of bifacial solar modules.



Tilt angle:

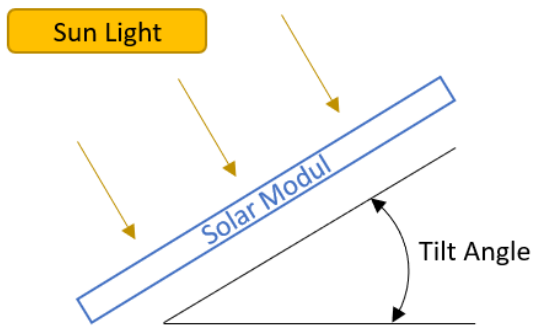

The solar modules must be set up at an angle of at least 10° to the ground. Building regulations must be observed.

Depending on the angle of inclination, the solar modules deliver a different yield. The optimal tilt angle depends on the location and the azimuth of the solar modules.

All solar modules that are connected in series should be aligned in the same way for an optimal energy yield.

## 5. MECHANICAL INSTALLATION

The solar modules must be mounted with a minimum distance of 5 mm to the next solar module.

Struts, mounting clamps, screws and other fixing elements must be commercially available and corrosion-free. In particular, the fixing elements must be designed in accordance with the local wind and snow loads. ASCE (American Society of Civil Engineers), IBC (International Building Code)

Avoid shading effects from the clamps and mounting system.

Use corrosion-proof mounting materials.

### 5.1 INSTALLATION WITH CLAMPS

When using mounting clamps, the solar modules are to be mounted on the struts in at least four locations on opposite sides. The clamps must be positioned inside the mounting zone. The solar module must be securely fixed. The clamps must not be in contact with the front glass or deform the frame in any way. Avoid shading effects from the clamps and mounting system.

It is recommended to use a clamp with a length of at least 40 mm. Avoid shading by the clamp. The maximum tightening torque for the mounting clamps can be obtained from the manufacturer of the clamps.

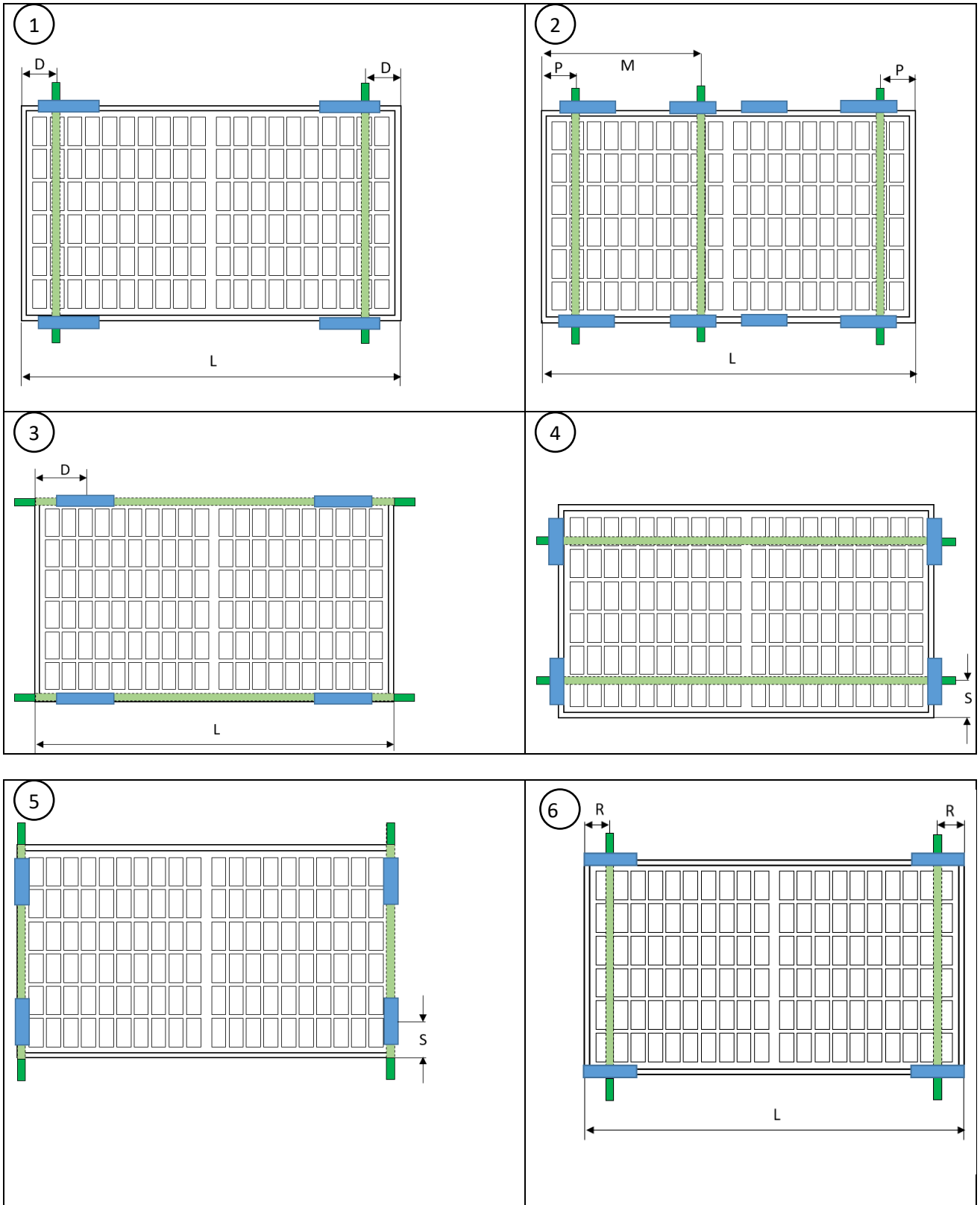

<ul style="list-style-type: none"> <li><span style="display: inline-block; width: 15px; height: 15px; background-color: #4F81BD; margin-right: 5px;"></span> clamping range</li> <li><span style="display: inline-block; width: 15px; height: 15px; background-color: #00A651; margin-right: 5px;"></span> substructure</li> </ul>	<p> <math>D = L/4^{+100}_{-100}</math> mm  <math>S = 100</math> to <math>300</math> mm  <math>P = L/4^{+0}_{-100}</math> mm  <math>R = 0</math> mm to <math>L/4 - 100</math> mm  <math>M = L/2^{+150}_{+50}</math> mm or <math>M = L/2^{-50}_{-150}</math> mm                      Ensure that the junction boxes do not touch the third mounting rail in case of deflection.                 </p>
--	--

Design loads\* (pressure / suction) for the permissible installation variants

Module type	Montagevariante					
	1	3	2	4	5	6
108-cells 120-cells 60-cells	3600/1600 Pa		3600/1600 Pa	1600/1600 Pa	1200/1200 Pa	1200/1200 Pa
144-cells 72-cells	1600/1600 Pa		3600/1600 Pa	-	-	-
132-cells	1600/1600 Pa		1600/1600 Pa	-	-	-

\*tested with 1.5 times higher test load perpendicular to the solar module plane

Example:

Module-Type	Module			Distance module fixing long side		Distance module mounting short side	
	Lenght [mm]	width [mm]	high [mm]	min [mm]	max [mm]	min [mm]	max [mm]
108 cells	1722	1134	30	330,5	530,5	100	300
	Lenght [inch]	width [inch]	high [inch]	min [inch]	max [inch]	min [inch]	max [inch]
108 cells	67.80	44.65	1.18	13.01	20.89	3.94	11.81

**5.2 INSTALLATION USING MOUNTING HOLES**

Solar module can be mounted with bolts at 4 (four) or 8 (eight) symmetrical quarter points.

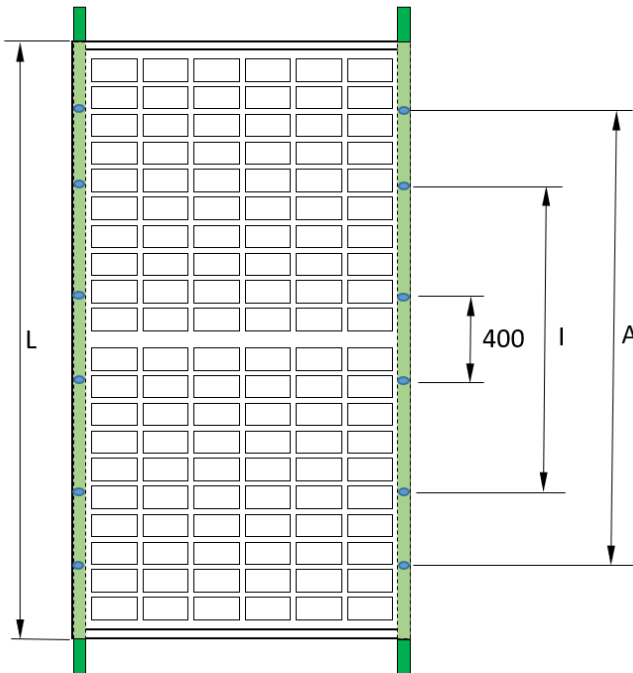

Mounting holes	screw	recommended Tightening torque
14*9 mm	M8	12,5 Nm - 18 Nm
10*6,5 mm	M6	8 Nm – 12Nm
10*7 mm	M6	8 Nm – 12Nm

Design load\* (Pressure/suction) with Mounting holes

Module type	Mounting variant		
	inner 4 holes (I)	outer 4 holes (A)	400 mm holes
108-cells 120-cells 60-cells	3600 Pa / 1600 Pa	1600 Pa / 1600 Pa	-
144-cells	1600 Pa / 1600 Pa	1600 Pa / 1600 Pa	1200 Pa / 1200 Pa
132-cells	1600 Pa / 1600 Pa	1600 Pa / 1600 Pa	1200 Pa / 1200 Pa

\*tested with 1.5 times higher test load perpendicular to the solar module plane

144 cell XXL and 132 cell XQ solar modules have an additional 4 mounting holes with 400mm spacing, which are suitable for the tracking bracket system products.

**5.3 INSTALLATION WITH INSERTION SYSTEMS**

Individual approvals can be requested for insertion systems if no approval is available from the insertion system manufacturer.

## 6. ELECTRICAL INSTALLATION

The electrical connection of the individual solar modules to each other and the connection to the inverter must be made with the connectors of the same type pre-mounted on the solar modules. The cables must not be used as carrying aids or bent and must not be installed under tensile stress. Only use special solar cables and suitable connectors that comply with the local specifications at the installation site.

<u>Connector model name</u>	<u>Allowable mating connector model name</u>
PV-JM608	PVJM608
PV-KST4 / PV-KST4-EV02 / PV-KST4-EV02A (STAEUBLI Multi- Contact)	PV-KST4 / PV-KST4-EV02 / PV-KST4-EV02A (STAEUBLI Multi- Contact)

Only certified solar cables may be used for earthing and connecting the modules (e.g. EN 50618 or IEC 62930 approved). The recommended minimum cross-section of the cable is 4 mm<sup>2</sup> (#12 AWG) and they must be heat-resistant up to at least 90°C. The minimum bending radius is 5x the cable diameter.

Secure the cable to the mounting system with UV-resistant cable ties and avoid direct sunlight on the cables.

Cables and connectors must not rest on the roof cladding and must not lie in the water-bearing plane.

The electrical installation and commissioning must only be carried out by a qualified electrician who knows the relevant standards and regulations for the use and assembly of solar modules. If not otherwise specified, it is recommended that the requirements of the U.S. National Electrical Code (NEC) or respective European Code and other countries Code be followed. Our operating instructions do not enable persons lacking the knowledge to assemble the solar module.

Solar modules must not be operated under short-circuit conditions.

**Disconnecting solar module plug connections during operation can lead to electric arcs (tear-off sparks) and thus endanger persons and property. Do not insert any objects into the plugs and sockets!**

**Non-compliance with this installation instruction may result in property damage and/or physical injury. AXITEC LLC will not be liable for compensation of any loss or injury caused by this type of non-compliance.**

### 6.1 ELECTRICAL PROPERTY

The electrical characteristics are within ±3% percent of the indicated values of I<sub>sc</sub>, V<sub>oc</sub>, and P<sub>max</sub> under standard test conditions (irradiance is 100 mW/cm<sup>2</sup>, AM 1.5 spectrum, and a cell temperature of 25°C (77°F)). A solar module with exposed conductive parts is considered to be in compliance with UL 1703 only when it is electrically grounded in accordance with the instructions presented below and the requirements of the National Electrical Code (NEC).

For installations in Canada, shall be in accordance with CSA C22.1, Safety Standard for Electrical Installations, Canadian Electrical Code, Part 1.

Connect the maximum number of solar modules that corresponds to the voltage specifications of the devices used in the system. The solar modules (in accordance with protection class II) must not be operated with a higher voltage than the permitted system voltage. The specifications can be found in the datasheet of the solar modules or in the datasheet of the relevant inverters. Please ensure

that the cables are installed and fixed in such a way that, in particular, the plug-in connections do not lie in a water-carrying plane.

All connected electrical components must be designed for the maximum operating voltage of the system.

Due to special environmental conditions, a solar module may supply a higher current and/or voltage than specified under the standardized test conditions. When designing PV systems, the values for  $I_{sc}$  and  $U_{oc}$  should be multiplied by a factor of 1.25 to determine the nominal values for components such as, e.g., cabling, fuses and inverters which will be connected to the output of the solar modules.

To determine the maximum possible number of solar modules per string, the open-circuit voltage at the lowest temperature must be considered:

$$U_{system,max} \geq N \times U_{oc,STC} [1 + \beta_{U_{oc}} \times (\vartheta_{min} - 25)]$$

$N$  = number of seriell modules;

$\beta_{U_{oc}}$  = temperature coefficient of  $U_{oc}$ ;

$\vartheta_{min}$  = minimum temperature at location

The specified protection classes are to be observed, however, the minimum compliance required is IP65. Ensure a gapless connection when connecting the plug-in connectors.

For a series connection, only solar modules with the same current rating should be used, and for a parallel connection, only solar modules with the same voltage rating should be used. Solar modules can be connected in series by connecting the positive connection of one solar module to the negative connection of the next solar module.

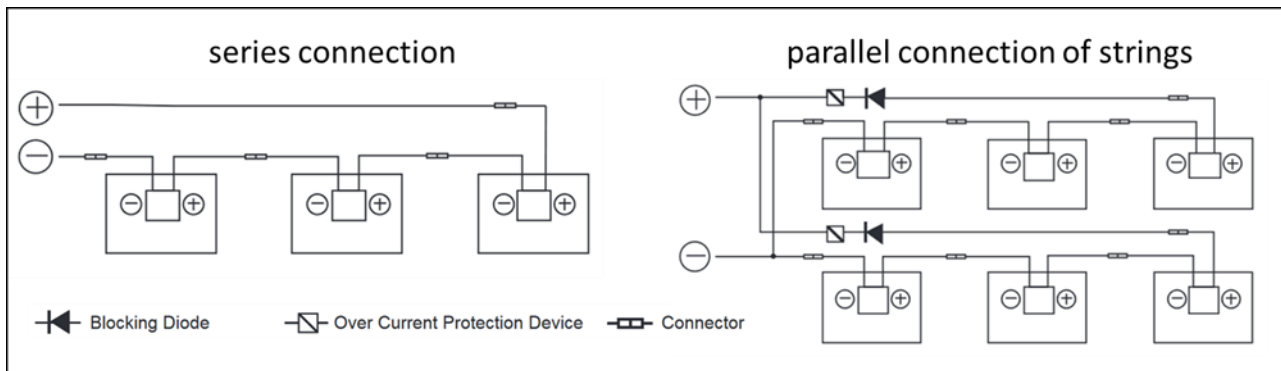

Suitable overcurrent protection measures (e.g. string cut-out) are required for the parallel connection of the solar modules. It must be ensured that the specified capacity regarding the return current  $I_R$  of the datasheet will not be exceeded. If there are more than two parallel strings, string fuses and string diodes must be used.

In a shaded system the solar modules or solar module strings should be connected in parallel.

Only use special solar cables and suitable plugs. Attach the cables to the mounting system using UV-resistant cable ties and avoid exposing the cables to direct sunlight.

In order to reduce voltages caused by lightning strikes, the surface area of all conductor loops must be as small as possible. Solar modules shall be installed in such a way that sufficient air circulation will be possible to prevent an overheating of the solar modules and components.

## 6.2 BYPASS DIODE

AXITEC LLC solar module junction box contains bypass diode which is in parallel connection with the cell strands. If heat spot occurs locally with the solar module, the diode will come into operation to stop the main current from flowing through the heat spot cells in order to restrain solar module heating and performance loss. Notice, bypass diode is not the overcurrent protection device.

If the diode is found or doubted to be out of order, the installer or system maintenance supplier should contact AXITEC LLC. Please do not try to open the solar module junction box on your own. There are 3 bypass diodes installed.

## 6.3 GROUNDING

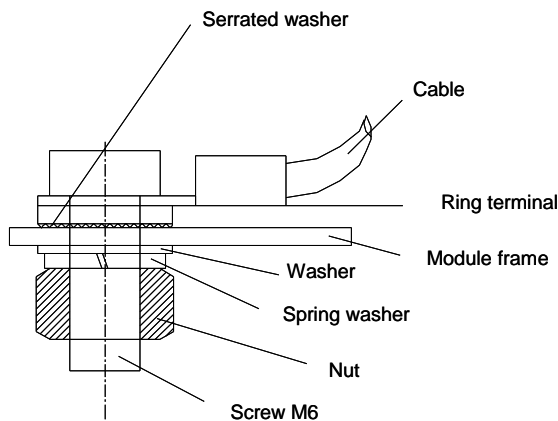

The solar modules are to be grounded according to the country-specific requirements and laws. If a lightning protection system is already present or intended to be installed on the building, the PV system is to be integrated into the protection concept against direct lightning strike. If a transformer less inverter is used, equipotential bonding may be prescribed in accordance with the inverter manufacturer's specifications. Country-specific laws like NEC must be observed.

Earth is indicated on the solar module frame. The earthing holes must remain unobstructed and must not be covered. Earthing of the solar modules shall only be carried out at the locations on the frame profile specified for this purpose via an earth cable that is connected electrically conductive

with the frame.

Country-specific standards are to be adhered to.

## **7. MAINTENANCE AND CLEANING**

### **7.1 MAINTENANCE**

We recommend regular inspections:

- Regularly check the solar module for signs of damages and glass breakage
- Check that all electrical connections are secure and free of corrosion.
- Check that the cables are undamaged.
- Check that the mounting system is securely attached and firm.

The most common causes for a low energy yield are:

- Improper or faulty wiring
- Burned-out fuses or triggered power switches .
- Shading of the solar modules by trees, masts or buildings
- Failure of the inverter
- Improper maintenance and cleaning
- Build-up of dirt on the solar modules
- Unsuitable angle of inclination or alignment of the solar modules

### **7.2 CLEANING**

Given a sufficient inclination ( $\geq 15^\circ$ ), the solar modules will generally require no cleaning (self-cleaning through rain). If they are installed in a flat angle and/or there is a lot of dirt/dust around, cleaning may be helpful from time to time to maintain a high energy yield.

**Cleaning a photovoltaic system creates a risk for electric shocks and damage to modules and other components. Therefore, we only recommend cleaning to trained personnel with knowledge of the risk of applying water to electrical components and equipped with Personal Protective Equipment. Damaged modules create a higher risk of electrical shock. Inspect the modules before cleaning. To reduce the risk of electrical shock, the system should be shut down and cleaning should take place in low light conditions.**

**Requirements to the cleaning process:**

- No dry cleaning of the modules.
- For cleaning, rainwater may be used or tap water with a total hardness lower than 75 mg/L.
- If running Water is not sufficient to clean heavy soiling, use a soft, non-conductive sponge or similar tool. If necessary, a non-abrasive non-caustic and mild detergent for glass cleaning may be used to support the cleaning process.
- Do not use high pressure cleaning and do not brush the backside of the modules. It is forbidden to stand or walk on modules.
- The difference between module temperature and water temperature must not exceed 20 K.



## **8. DISCLAIMER OF LIABILITY**

AXITEC LLC does not assume responsibility and expressly disclaims liability for any loss, damage, or expense arising out of, or in any way connected with installation, operation, use, or maintenance by using this manual. AXITEC LLC assumes no responsibility for any infringement of patents or other rights of third parties, which may result from use of solar modules. No license is granted by implication or under any patent or patent rights. The information in this manual is reliable but does not constitute an expressed and/or implied warranty. AXITEC LLC reserves the right to make changes to the product, specifications, or this manual without prior notice. Without any prior written authorization, AXITEC LLC will not accept any returned solar modules.

These installation and assembly instructions apply to generally common systems. All specifications are provided without warranty. AXITEC LLC does not guarantee the solar modules' fitness for use or function in case of any deviation from the notes contained in this user information. Because the adherence to this user information and the conditions and methods of the installation, the operation, the use and the maintenance of the solar modules cannot be controlled or monitored by AXITEC LLC. AXITEC LLC accepts no liability for damages caused by any use other than the intended use, faulty installation, operation, use or maintenance.

Furthermore, any liability for violations of patent rights or violations of other rights of third parties arising from the use of the solar modules is excluded, provided there is no liability obligation to this effect imposed by law.